

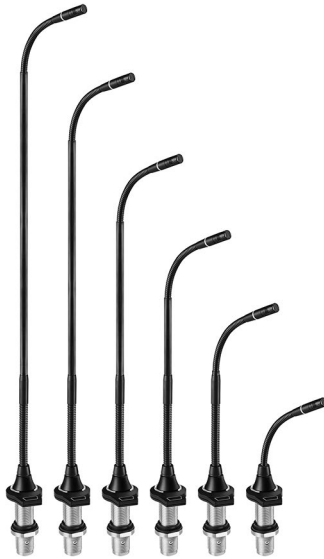

ES925C6/FM5  
ES925C12/FM5  
ES925C15/FM5  
ES925C18/FM5  
ES925C21/FM5  
ES925C24/FM5

User Manual  
CARDIOID CONDENSER  
MODULAR GOOSENECK MICROPHONE  
WITH 5-PIN FLUSH-MOUNT POWER MODULE



audio-technica

## ■ Introduction

Thank you for purchasing this product. Before using the product, read through the user manual to ensure that you will use the product correctly. Please keep this manual for future reference.

## ■ Features

- Modular microphone system comprised of an ES Series capsule, gooseneck assembly, and power module.
- RGB LEDs built into both the flush-mount power module and gooseneck assembly indicate the on/off status of the microphone.
- Includes external control function for device control from the capacitive touch switch.
- The capacitive touch switch can be set to any of three operating modes: "touch-on/touch-off", "touch-to-talk" and "touch-to-mute".

## ■ Safety precautions

Although this product was designed to be used safely, failing to use it correctly may result in an accident. To ensure safety, observe all warnings and cautions while using the product.

## ■ Cautions for the product

- Do not subject the product to strong impact to avoid malfunction.
- Do not disassemble, modify or attempt to repair the product.
- Do not handle the product with wet hands to avoid electric shock or injury.
- Do not store the product under direct sunlight, near heating devices or in a hot, humid or dusty place.

## ■ Notes on use

- Check the strength of the mounting area. Insufficient strength or poor mounting will cause objects to fall or become damaged.
- The circuitry in the microphone takes about 30 seconds to stabilize after power is supplied. You may hear some audio disturbance during startup.
- Install the microphone on a flat, unobstructed mounting surface.
- Depending on the surface finish of a table, the isolators may leave marks on the table.
- Do not excessively bend the gooseneck assembly, rotate the ends of the capsule, or pull on them. Doing so may cause disconnection or malfunction.
- The product is a modular system comprised of a microphone element, gooseneck assembly and power module. Make sure the parts are firmly attached before use.
- Do not remove the rubber O-ring on the power module connecting part at the lower section of the gooseneck assembly.
- When attaching parts, remove the black cap on the capsule connecting part of the gooseneck assembly. **Do not remove the silicone part at the end of the capsule connecting part.**



## ■ Assembly

- Insert the gooseneck assembly (c) while rotating it into the flush-mount power module (d).
- Tighten until it does not rotate, and use the hex wrench (i) to tighten the set screw (h) and set the gooseneck assembly in place.
- Connect the capsule (b) to the gooseneck assembly, and attach the windscreen (a).
- \* If the parts are not sufficiently tightened together, problems may occur such as the LED colors of the gooseneck assembly and power module not matching or sound is not output.
- Refer to the LED table to the right and set the LED color before attaching to the mounting surface.
- If you are installing the flush-mount power module on a table without the isolators, you must make a hole with a diameter of 20.5 mm in the mounting surface.
- If you are installing with the isolators, the hole must have a diameter of 23.5 mm. Inserting the isolators between the mounting surface and power module allows you to separate the flush-mount power module from the mounting surface.
- Attach the upper part isolator (e) to the mounting surface, and attach the flush-mount power module (d). Attach the lower isolator (f) to the reverse side of the mounting surface, and then tighten the nut (g).

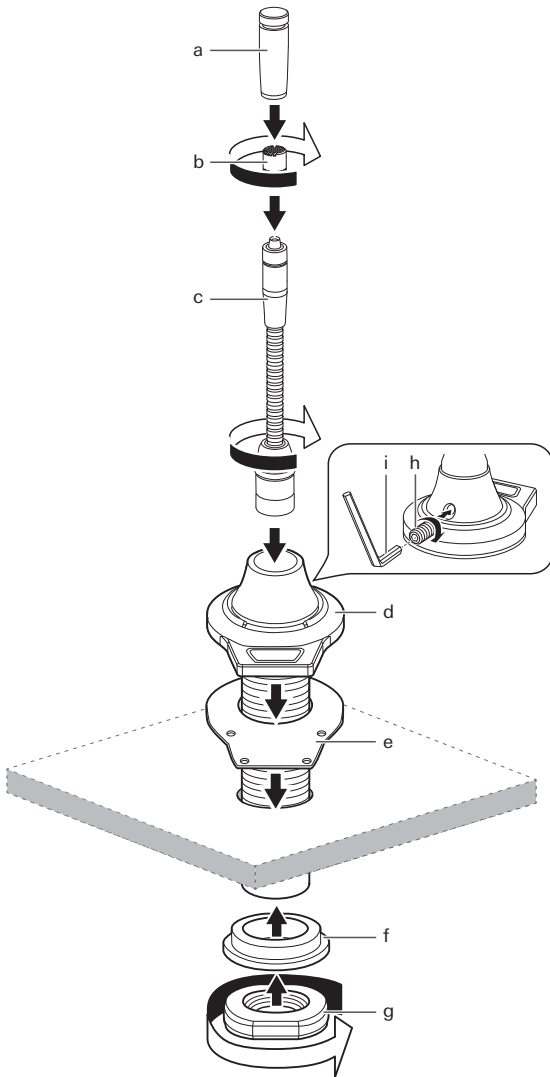

## ■ Switch setting and functions

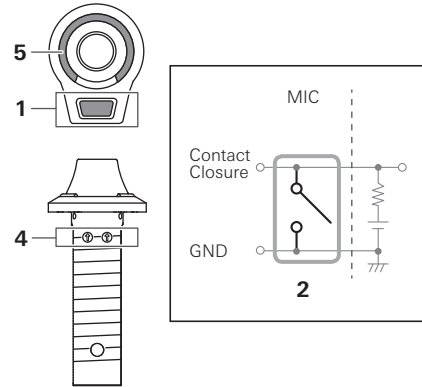

1. Action	2. Contact closure status	3. Audio status	4. LED color	5. LED status
			LED COLOR MIC OFF: MIC ON:	
			MIC OFF: MIC ON:	
			MIC OFF: MIC ON:	

## ■ LED color

▼	1	2	3
OFF	RED	GREEN	YELLOW
4	5	6	7
BLUE	MAGENTA	CYAN	WHITE

## ■ Wiring

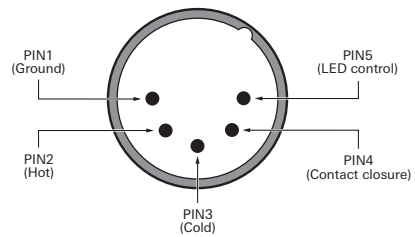

## Specifications

### ES925Cx/FM5

x = 6/12/15/18/21/24

Element	Fixed-charge back plate, permanently polarized condenser
Polar pattern	Cardioid
Frequency response	30 - 20,000 Hz
Open circuit sensitivity	-40 dB (10.0 mV) (0dB=1V/Pa, 1kHz)
Impedance	130 ohms
Maximum input sound level	140 dB SPL (1kHz at 1% THD)
Dynamic range	112 dB (1kHz at Max SPL)
Signal-to-noise ratio	66 dB (1kHz at 1Pa, A-weighted)
Phantom power requirements	22 - 52 V DC, 7.6 mA

#### Contact closure

Closure input voltage	-0.5 - 5.5 V
Maximum permissible power	200 mW
On-resistance	100 ohms

#### LED control

Active high (+5 V DC) TTL compatible	Active low voltage	1.2 V or lower
Maximum permissible input power	Maximum permissible power	200 mW

#### Weight

ES925C6/FM5:	109 g (3.8 oz)
ES925C12/FM5:	133 g (4.7 oz)
ES925C15/FM5:	138 g (4.9 oz)
ES925C18/FM5:	143 g (5.0 oz)
ES925C21/FM5:	148 g (5.2 oz)
ES925C24/FM5:	153 g (5.4 oz)

#### Dimensions

ES925C6/FM5:	207.6 mm (8.2") x 38 mm (1.5") x 48 mm (1.9")
ES925C12/FM5:	315 mm (12.4") x 38 mm (1.5") x 48 mm (1.9")
ES925C15/FM5:	391.2 mm (15.4") x 38 mm (1.5") x 48 mm (1.9")
ES925C18/FM5:	467.4 mm (18.4") x 38 mm (1.5") x 48 mm (1.9")
ES925C21/FM5:	543.6 mm (21.4") x 38 mm (1.5") x 48 mm (1.9")
ES925C24/FM5:	619.8 mm (24.4") x 38 mm (1.5") x 48 mm (1.9")

Output connector 5-Pin XLRM-type

#### Optional interchangeable elements

ESE-Ha (100°), ESE-Oa (360°), ESE-MLa (90°)

Included accessories Isolator 1 pair, Nut, Windscreen AT8109a, Set screw (M2x2 mm (0.08")) 2 pcs., Hex wrench (0.89 mm (0.04"))

## Polar pattern

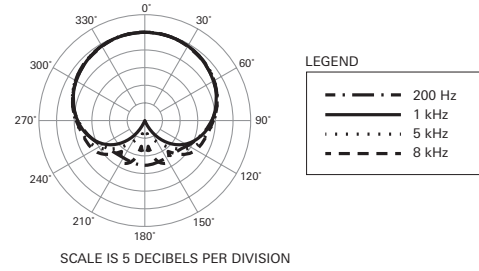

## Frequency response

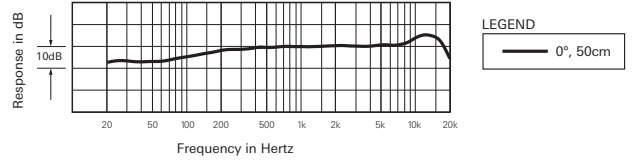

## Dimensions

