

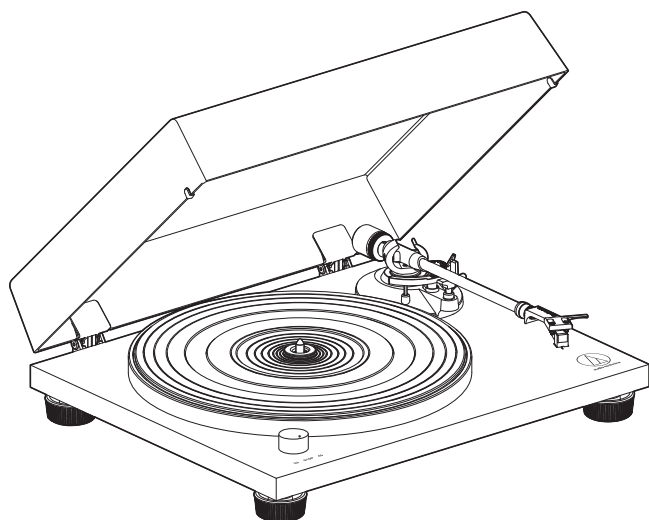

AT-LPW40WN

User Manual
Belt-Drive Turntable



Introduction

Thank you for purchasing this Audio-Technica product.

Before using the product, read through this user manual to ensure that you will use the product correctly. Please keep this manual for future reference.

This product can be used only in the countries where the product is sold. Make sure that the operating voltage and the plug of AC adapter of the product are correct for the country you live in.

Package contents

Make sure that you have all the included items listed below before using this product.

If some items are missing or damaged, contact your local Audio-Technica dealer.

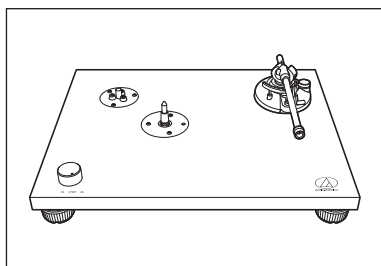

• Turntable body

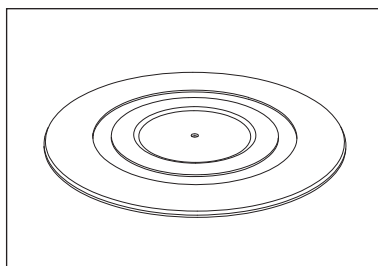

• Turntable mat

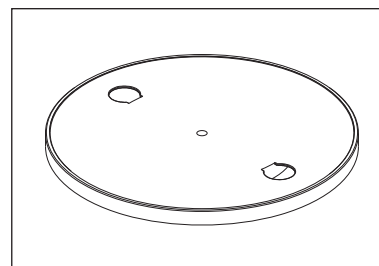

• Platter

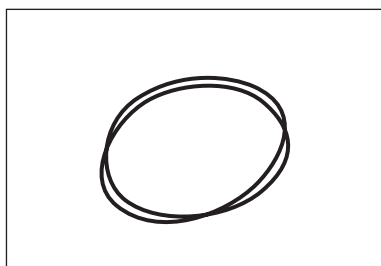

• Drive belt

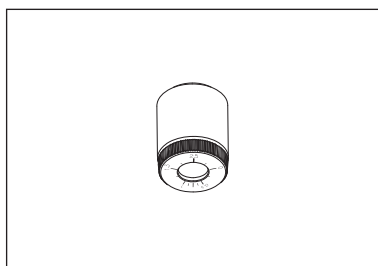

• Counterweight

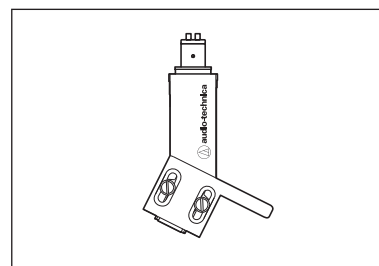

• Headshell (AT-HS4) with VM stereo cartridge*

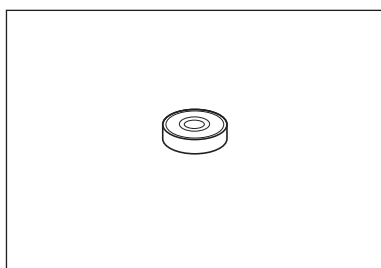

• 45 RPM adapter

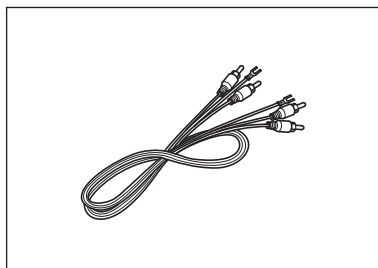

• RCA audio cable (Approx. 1.0 m (3.3'))

- Dust cover
- Dust cover hinges
- AC adapter (Approx. 1.5 m (4.9'))
- Quick start guide
- Caution guide

* AT-LPW40WN: AT-VM95E

After purchase, we suggest that you save all packaging materials for possible future storage, moving, or shipping.

Safety precautions

Important information

Warning:

- To prevent fire or shock hazard, do not expose this apparatus to rain or moisture.

Caution:

- Do not expose this apparatus to drips or splashes.
- To avoid electric shock, do not open the cabinet.
- Refer servicing to qualified personnel only.
- Do not expose this apparatus to excessive heat such as sunshine, fire or the like.
- Do not subject this apparatus to strong impact.
- This apparatus should be located close enough to the AC outlet so that you can easily grasp AC adapter at any time.
- In case of emergency, disconnect the AC adapter quickly.
- Do not place any objects filled with liquids, such as vases, on this apparatus.
- To prevent fire, do not place any open flame sources (such as lighted candles) on this apparatus.
- Do not install this apparatus in a confined space such as a bookcase or similar unit.
- Install this apparatus only in the place where ventilation is good.
- The rating label is put on the bottom of this apparatus.

For customers in the USA

FCC Notice

Warning:

This device complies with Part 15 of the FCC Rules. Operation is subject to the following two conditions: (1) This device may not cause harmful interference, and (2) this device must accept any interference received, including interference that may cause undesired operation.

Caution:

You are cautioned that any changes or modifications not expressly approved in this manual could void your authority to operate this equipment.

Note: This equipment has been tested and found to comply with the limits for a Class B digital device, pursuant to part 15 of the FCC Rules. These limits are designed to provide reasonable protection against harmful interference in a residential installation. This equipment generates, uses and can radiate radio frequency energy and, if not installed and used in accordance with the instructions, may cause harmful interference to radio communications. However, there is no guarantee that interference will not occur in a particular installation. If this equipment does cause harmful interference to radio or television reception, which can be determined by turning the equipment off and on, the user is encouraged to try to correct the interference by one or more of the following measures:

- Reorient or relocate the receiving antenna.
- Increase the separation between the equipment and receiver.
- Connect the equipment into an outlet on a circuit different from that to which the receiver is connected.
- Consult the dealer or an experienced radio/TV technician for help.

Safety precautions

For customers in Canada

IC statement:

CAN ICES-3 (B)/NMB-3(B)

Notes on use

Turntable body

- Do not place and use the product in locations that are considerably hot or humid, dirty, or subject to extreme vibrations.
- The product should be positioned on a flat, level surface.

Cartridge

- Attach the protector to protect the stylus when the product is not in use.
- Do not touch the stylus of the cartridge with your finger.
- Do not allow the cartridge's stylus to bump against the platter or the edge of the record.

Part names and functions

Overall diagram

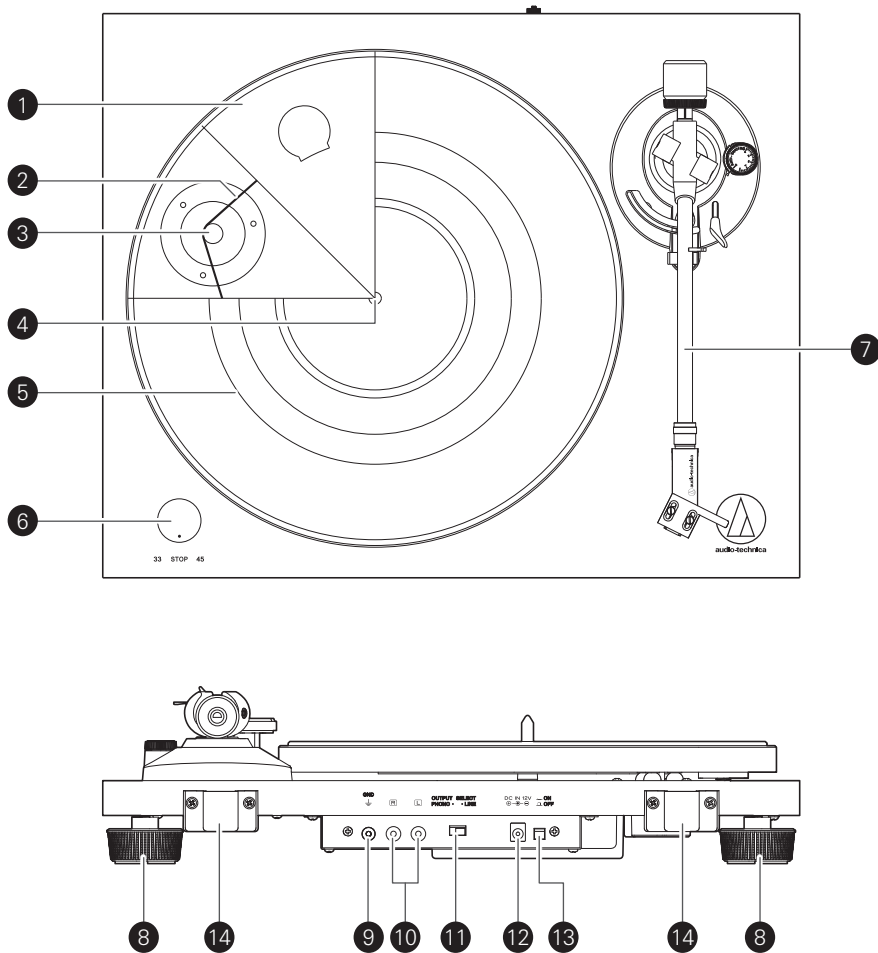

- 1** Platter
- 2** Drive belt
Installation is required for operation.
- 3** Motor pulley
- 4** Spindle
- 5** Turntable mat
- 6** Control knob
Use to start and stop, as well as select the platter's speed.
- 7** Tonearm
For details, refer to "Tonearm" on p. 4.
- 8** Feet
Adjust the level of the product.
- 9** Ground (earth) terminal
Connect the amplifier's ground (earth) terminal to this terminal using the RCA audio cable's ground conductor.
- 10** Stereo output terminals
Connect the RCA audio cable. Connect it to either the amplifier's PHONO input jack or its line input jack. The red terminal is the right channel and the white terminal is the left channel.
- 11** Output selector switch
If connecting to an amplifier's PHONO input jack, set this switch to the PHONO position. If connecting to the AUX jack of an amplifier, set this switch to the LINE position.
- 12** Power input jack
Connect the AC adapter.
- 13** Power switch
Switch ON/OFF.
- 14** Dust cover hinge holder

Part names and functions

Tonearm

- 1 Counterweight
Balances the tonearm and adjusts to provide the proper tracking force.
- 2 Tracking force gauge ring
Use to adjust and set the tracking force.
- 3 Tonearm lift
Moves the tonearm vertically to and from the face of the record.
- 4 Tonearm rest with clamp
Use the clamp to secure the tonearm so that it does not move.
- 5 Anti-skate control dial
While the record is playing, a force acts on the stylus tip to pull it inward. This force can be counteracted by setting the same values for anti-skate and the tracking force.
- 6 Tonearm lift control lever
Operates the tonearm lift.
- 7 Tonearm
- 8 Locking ring
Rotate the ring to the left (counterclockwise) to secure the headshell. To remove the headshell, rotate the ring to the right.
- 9 Headshell and cartridge
The cartridge is attached to the headshell (AT-HS4).

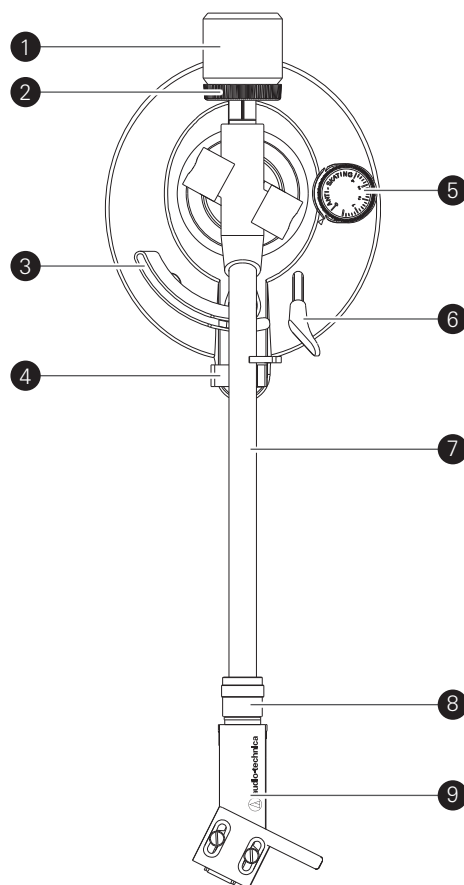

Preparation for use

Placing the platter

This product requires some assembly before using it for the first time. Do not connect the AC adapter until assembly is complete.

1. Set the platter on the spindle.

- To avoid damaging the spindle when seating the platter, align the position of the spindle and the platter's hole, and then slowly seat the platter.
- Make certain that the platter is fully seated on the spindle.

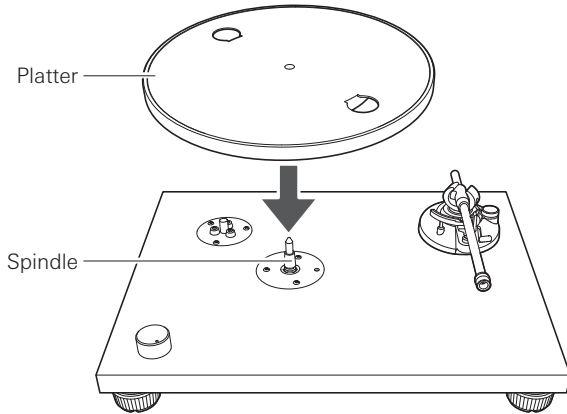

2. Install the belt to the platter drive ring under the platter making sure the belt is flat when seated, and then attach the belt to the motor pulley.

- Make sure that the belt does not get twisted.

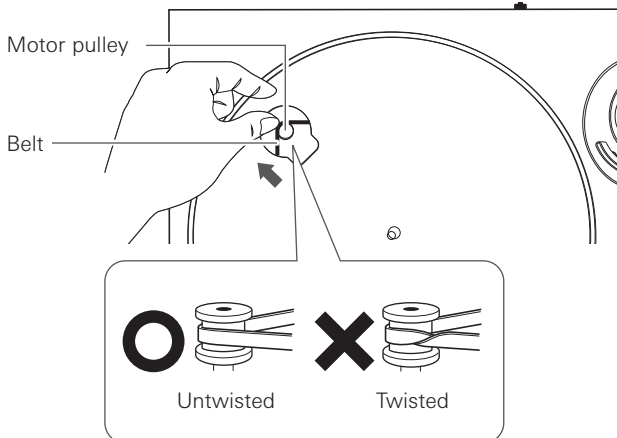

Setting up the turntable

- Position the product on a level surface.
- To avoid the effects of vibrations and acoustic pressure, do not mount the product next to such items as speakers.
- The product may pick up radio static if placed next to a radio. Therefore, try to keep the product away from radios.
- If the product is near equipment (cell phone, etc.) that emits strong radio waves, noise may occur.

Leveling the turntable

1. After positioning the product where you want to use it, adjust the feet so that the product is level.
 - Use a level (sold separately) as needed to ensure that the product is level.

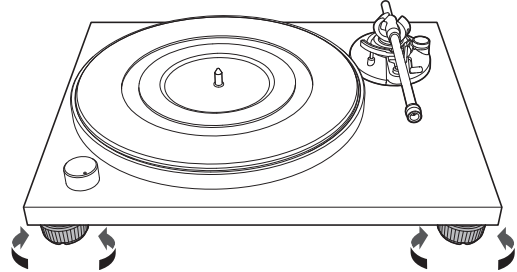

Assembling the tonearm

1. Remove the cable tie used to secure the tonearm at the time of delivery.
 - Use the clamp to temporarily secure the tonearm to the tonearm rest.
2. Insert the headshell into the tonearm.
 - Hold the right and left edges of the headshell so that you do not damage the stylus or cut the cartridge's wires.

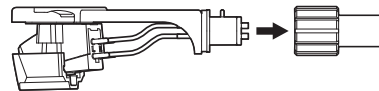

3. With the headshell inserted, turn the locking ring counterclockwise (to the left).

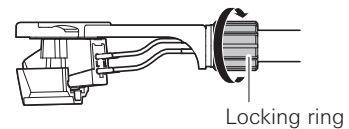

4. With the tracking force gauge ring facing forward, attach the counterweight to the back of the tonearm, and slowly turn it counterclockwise (to the left until it clicks on).

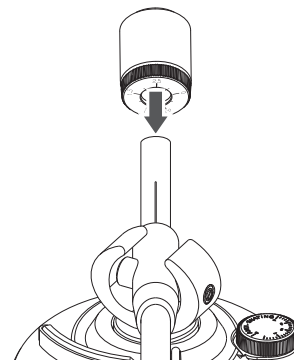

Preparation for use

Tonearm balance and tracking force

In order for the cartridge to reproduce audio correctly from the record's grooves, the tonearm's balance and tracking force must be adjusted to fit the specifications of the cartridge. If the tonearm's balance and tracking force are not properly adjusted, the record or the cartridge's stylus may become damaged.

- Do not drag the cartridge's stylus across the record or turntable mat when adjusting the tonearm's balance or tracking force. Doing so may damage the stylus.

Setting tonearm balance

1. Remove the cartridge's protector.

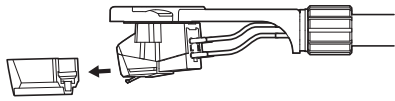

2. Unlock the tonearm and lift the tonearm lift control lever.

- The tonearm is tilted because the balance has yet to be adjusted.

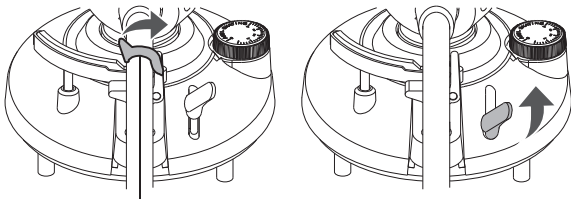

3. Place the tonearm over the platter. Hold the headshell and lower the tonearm lift control lever completely.

- Protect the stylus from touching platter.

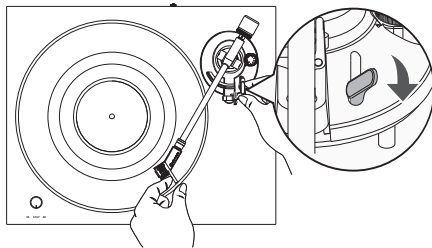

4. While still lightly holding the headshell, turn the counterweight to adjust the tonearm's balance.

- Adjust the balance so that the tonearm is level when you release the headshell.

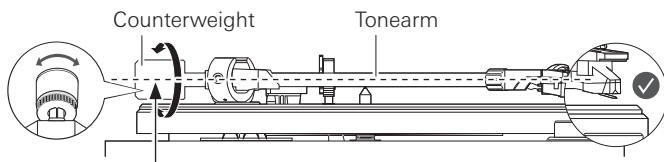

Adjust so that tonearm is level

5. Return the tonearm to the tonearm rest.

Setting tracking force

1. While supporting the counterweight so that it does not move, turn the tracking force gauge ring so that its "0" position lines up with the centerline on the back of the tonearm.

- The tracking force is not adjusted simply by turning the tracking force gauge ring.

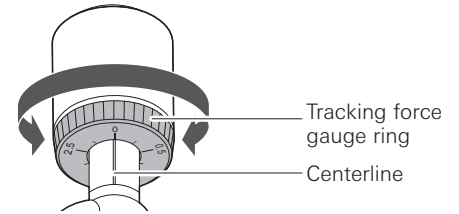

2. Turn the counterweight and the tracking force gauge ring together counterclockwise from the 0 position (to the left) until the centerline value matches the recommended tracking force value for the cartridge you are using.

- Refer to the cartridge maker's specifications for the recommended tracking force value.
- The tracking force value for the cartridge provided with this product is 2.0 g.

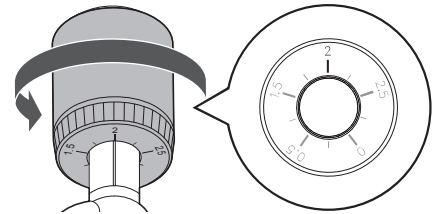

Setting the anti-skate adjustment

While the record is playing, a force acts on the stylus tip to pull it inward. This force can be counteracted by setting the same values for anti-skate and the tracking force.

1. Adjust the anti-skate control dial to have the same value as the tracking force value.

- The tracking force value for the cartridge provided with this product is 2.0 g.

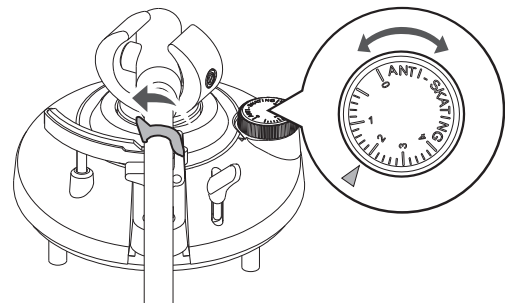

Preparation for use

Installing/removing the dust cover

When attaching the dust cover, insert the hinges of the dust cover into the two dust cover hinge holders on the back of the body. When removing the dust cover, slowly pull the dust cover out from the dust cover hinge holders.

Setting output selector switch

This product has a built-in phono equalizer function. You can use the product, even if you do not have a phono amplifier or connectable equipment with a built-in phono amplifier, by connecting an active speaker, etc.

Use the output selector switch to set the output, as shown below.

Connectable equipment being used	Position of output selector switch	Where to connect the RCA audio cable
Device with phono input	PHONO	Phono input jack and ground (earth) terminal of connectable equipment
Device without phono input	LINE	AUX or line input jack of connectable equipment
PC sound card	LINE	Sound card's line input jack*

* An audio adapter (sold separately) may be required to connect the RCA audio cable to the PC sound card's line input jack.

Connecting to connectable equipment (active speakers, amplifiers, etc.)

Align the settings for the output selector switch and connect the RCA audio cable to an input jack that is compatible with the connectable equipment you are using (amplifier, receiver, active speakers, sound card, etc.).

- The RCA audio cable's red jack is for the right (R) channel, and the white jack is for the left (L) channel.

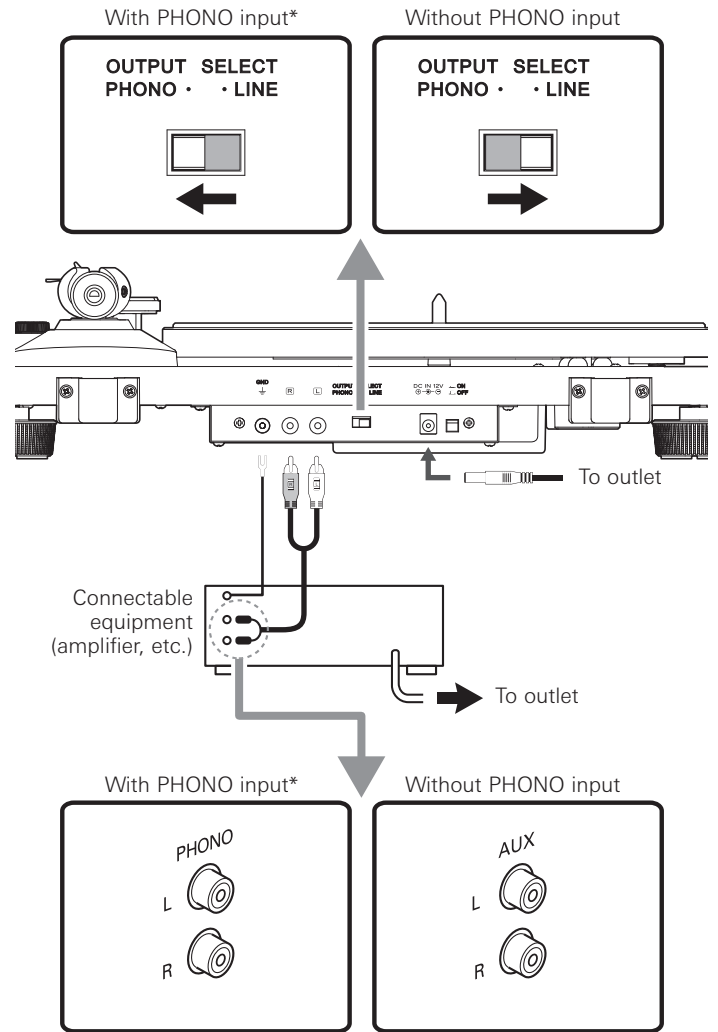

- * Depending on the equipment you are connecting, a ground (earth) terminal may exist near the phono input jack. If this is the case, connect to it using the ground line from the RCA audio cable. This will help prevent a low humming noise that might otherwise be heard during playback.

Connecting the AC adapter

- Connect the AC adapter's cord to the power input jack.
- Plug the AC adapter into an outlet.
 - Make sure that the power switch is in the "OFF" position and the control knob is in the "STOP" position. If the power switch is in the "ON" position with the AC adapter connected to the outlet, a standby current is always running through the product even it is not being used.
 - If you play a record immediately after plugging the AC adapter into an outlet, the sound that is played may be garbled. Wait a short time (about 30 seconds) after plugging the AC adapter into the outlet before playing a record.

Playing a record

Before playing a record

1. Remove the cartridge's protector.

- If the tonearm is fixed to the tonearm rest, remove the clamp.

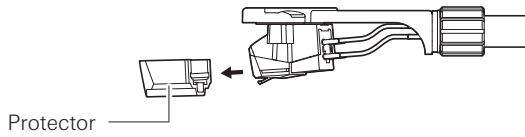

2. Place the record on the turntable mat so that the center hole aligns with the spindle.

- If playing a 45 RPM record, attach the 45 RPM adapter (see the diagram to the right below).

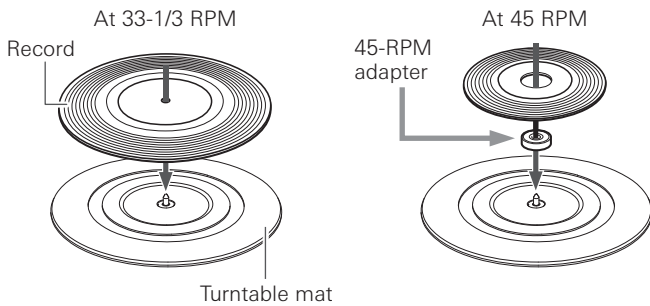

Playing a record

Lower the volume of the amplifier, speakers, etc., sufficiently.

1. Turn the power switch on.
2. Use the control knob to select the speed.
 - Select "33" for a 33-1/2 RPM record, or "45" for a 45 RPM record.
 - The platter begins spinning.
3. Raise the tonearm by lifting the tonearm lift control lever to the UP position.

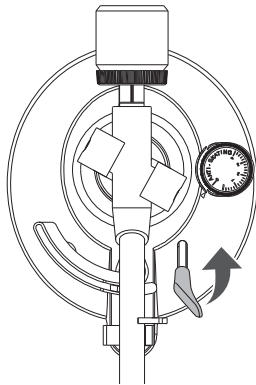

4. Position the tonearm over the desired location (groove) on the record.

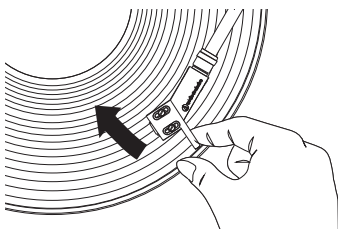

5. Lower the tonearm by moving the tonearm lift control lever to the DOWN position. The tonearm descends slowly onto the record and play begins.

- Alternatively, you can skip steps 2 to 4, and use your fingers to lift the headshell, move the tonearm over the desired location on the record, and then place the headshell down to begin playing the record.
- Do not subject the product to strong impact during playback.

Pausing the record

1. After lowering the volume of the amplifier, speakers, etc., sufficiently, lift the tonearm with the tonearm lift control lever.

Stopping the record

1. Lower the volume of the amplifier, speakers, etc., sufficiently.
2. Lift the tonearm lift control lever, return the tonearm to the tonearm rest, and fix it with the clamp.
3. Turn the control knob to the "STOP" position.
 - The platter slows down and rotation stops.

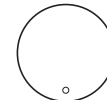

33 STOP 45

4. Remove the record after the platter has come to a complete stop.

- If the turntable mat gets dirty, it can easily scratch the record, so remove the turntable mat periodically and wipe off any dust.
- To prevent the record from becoming scratched or warped, remove it after use.
- Do not use a platter other than the one provided.
- This product is not intended for DJs. Do not touch the record or the turntable mat while the record is playing.

Care

Turntable body

- When the turntable body is dirty or dusty, first disconnect the AC adapter's cord from the power input jack, and then wipe off the dirt and dust with a soft, dry cloth.
- Do not use benzenes, thinners, etc.
- When storing the product for a long time, disconnect the AC adapter's cord from the power input jack and the power cable plug from the outlet then wrap the equipment in plastic; do not allow it to become damp.

Stylus tip

- If dirt and grime are stuck to the stylus tip, clean it with a commercially sold brush.
- We recommend using a stylus cleaner (sold separately) if the stylus tip is considerably dirty. Clean the stylus tip by moving the brush from the rear to the front of the stylus tip.

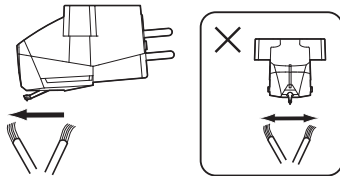

Replacing the stylus

Removing the stylus

- In addition to the deterioration of sound quality, records may also be damaged as the cartridge's stylus tip wears down.
 - As a rule of thumb, replace the stylus after 300 hours of use.
 - Be sure to disconnect the product's power cable plug from the outlet.
1. Release the headshell from the tonearm.
 - Fix the tonearm with the clamp and then remove the headshell gently.
 2. After lowering the cartridge's protector, remove the stylus by pulling in the direction of the arrow.

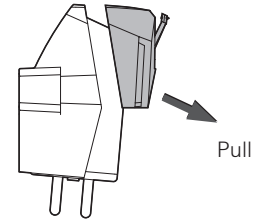

Installing a new replacement stylus

1. Mount the new replacement stylus to the cartridge.

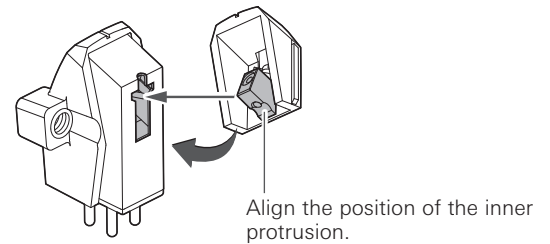

2. Mount the headshell onto the tonearm.

Replacing a cartridge

Refer to the user manual for the cartridge that you will be using if you are replacing the cartridge included with this product with another, commercially available cartridge. After you replace the old cartridge with a new one, you must readjust the overhang and the tonearm's balance and tracking force.

1. **Release the headshell from the tonearm.**
 - Use the clamp to secure the tonearm and then remove the headshell gently.
2. **Remove the stylus from the cartridge.**
 - Refer to "Removing the stylus" on p. 9.
3. **Remove the lead tips.**
 - Be careful not to damage the lead tips.
4. **Using a commercially sold, non-metallic slotted screwdriver, remove the installation screws, and then remove the cartridge from the headshell.**
5. **Refer to the user manual for the new cartridge for mounting instructions and connecting to the lead tips.**

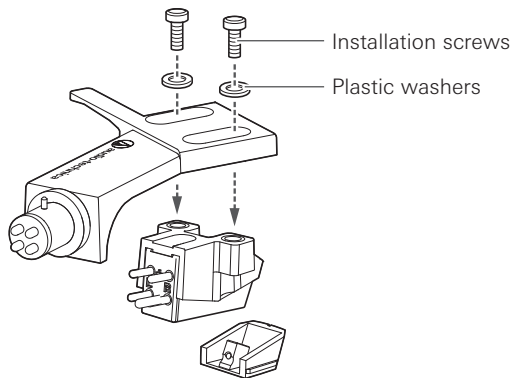

6. **Using a commercially sold, non-metallic slotted screwdriver, tighten the screws in both places, and then adjust the overhang.**
 - Refer to "Adjusting the overhang" on p. 11.
 - After the adjustments are complete, tighten the screws securely.
7. **Attach the headshell to the tone arm.**
8. **Adjust the tonearm's height.**
 - Refer to "Adjusting the tonearm's height" while doing the adjustments.
9. **Adjust the tonearm balance and tracking force.**
 - Refer to "Tonearm balance and tracking force" from p. 6.

Replacing the belt

- The belt is a consumable part. Replace the belt if the speed of playback slows down or irregular rotation occurs. As a rule of thumb, we suggest replacing the belt once a year.
- Before replacing the belt, be sure to disconnect the product's power cable plug from the outlet.

1. **Remove the old belt.**
2. **Attach the new belt to the platter first, and then attach it to the motor pulley.**
 - When attaching the belt to the motor pulley, make sure that the belt does not get twisted.

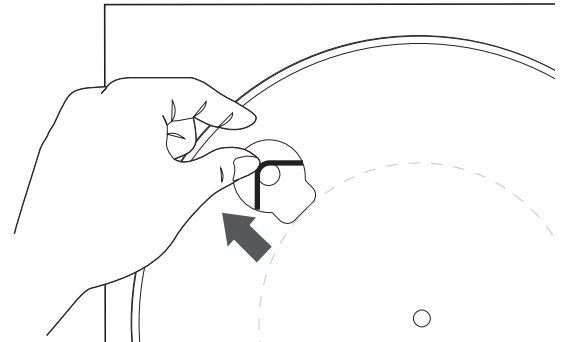

Adjusting the overhang

The position of the cartridge must be accurately determined (adjusting the overhang) when mounting a cartridge or headshell other than the one provided.

1. Mount the cartridge so it is parallel to the headshell.

- Match up the positions of the cartridge and headshell to the figure below and mount the cartridge so it is parallel to the headshell.

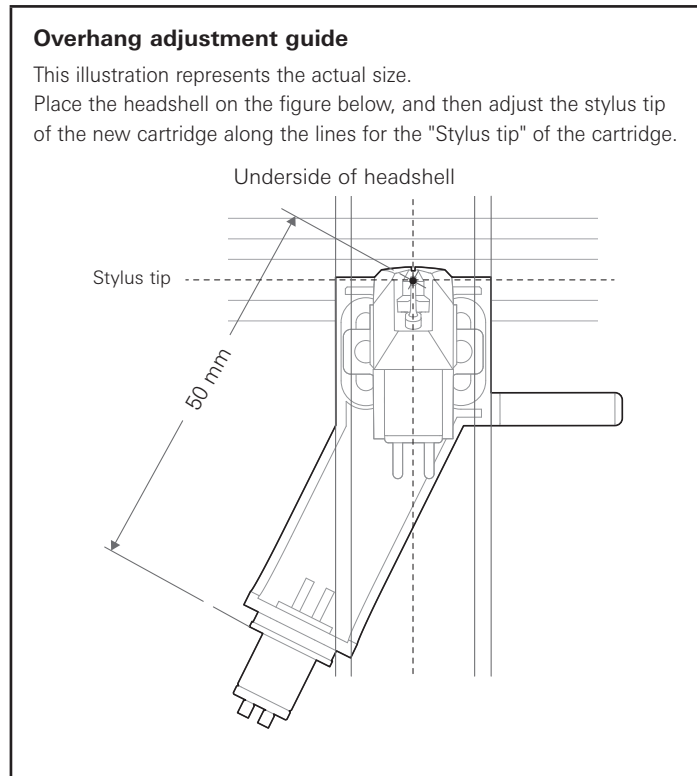

2. Mount the cartridge so it is perpendicular to the top of the headshell.

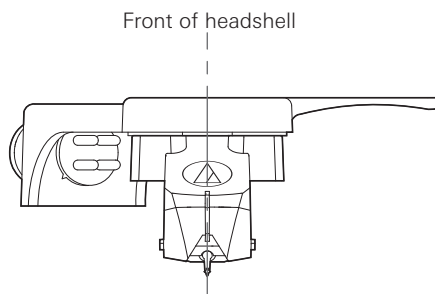

When the turntable is moved

Using the product's original packing materials, wrap the turntable in the reverse order from when you unwrapped it. If you do not have the packaging materials, take the following measures:

- After disconnecting the power cable plug from the outlet, remove the turntable mat and platter, and then wrap them so that they do not get damaged.
- Fix the tonearm with the clamp.
- Remove the counterweight.
- Remove the headshell from the tonearm with the protector attached to the cartridge, and then wrap the entire headshell assembly so that it does not get damaged.
- Wrap the turntable body with paper or a soft cloth so that it does not get damaged.

Troubleshooting

Problem	Solution
The platter does not spin.	<ul style="list-style-type: none"> • Is the AC adapter connected to the outlet? Connect AC adapter to the outlet. • Has the belt slipped from the platter? Correctly place the belt on the platter. • Is the belt placed on the motor pulley? Check that the belt is placed on the motor pulley correctly. • Has the belt been damaged? Replace it with a new belt.
The platter spins, but there is no sound or the volume is not loud enough.	<ul style="list-style-type: none"> • Are the function settings and input for connected equipment (amplifier, etc.) selected correctly? Check whether the settings for the connected equipment are correct. • Is the stylus damaged? Check the stylus and replace it, if necessary. • Is the stylus placed correctly on the body of the cartridge? Check the cartridge and adjust it, if necessary. • Are the setting positions for the output selector switch correct? Check that the output settings are correct, noting the following common problems and their causes: <ul style="list-style-type: none"> - If there is no sound, or if the volume is not loud enough, the product is set to the "PHONO" position and connected to the amplifier's AUX/LINE input. - If the volume is too loud or is distorted, the product is set to the "LINE" position and connected to the amplifier's PHONO input. • Is the tracking force set too heavy? Adjust the tracking force.
The stylus skips.	<ul style="list-style-type: none"> • Is the tracking force set too light? Adjust the tracking force. • Is the anti-skate set improperly? Verify anti-skate is set for same value as cartridge tracking force. • Is the record warped? Check the record. • Is the record scratched? Check the record. • Is the stylus dirty? Excess build up around the stylus tip will effect tracking.
There is howling.	<ul style="list-style-type: none"> • Is the product picking up excessive vibrations from the floor, surfaces of the walls, or nearby speakers? Decrease the vibrations or mount the product on a surface that is not subject to the effects of vibrations. • Is the product mounted on an unstable surface? Check whether the surface on which the product is mounted is suitable.
There is noise when the record is playing.	<ul style="list-style-type: none"> • Is there dust on the cartridge's stylus tip? If dust is stuck to the stylus tip, clean it with a commercially sold brush.
The sound when the record is playing is either too fast or too slow.	<ul style="list-style-type: none"> • Are the speed settings for the product correct? Use the control knob to select the correct speed for the type of record being played.
Playing speed slows down or there is irregular rotation.	<ul style="list-style-type: none"> • Is the belt stretched out? Replace it with a new belt.
Humming is heard during playback.	<ul style="list-style-type: none"> • Is the ground line connected correctly? Make sure the ground line is properly connected. • Is the headshell attached to the tonearm firmly? Make sure the locking ring is tight.

Dimensions

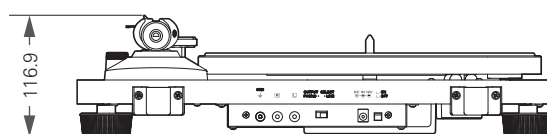
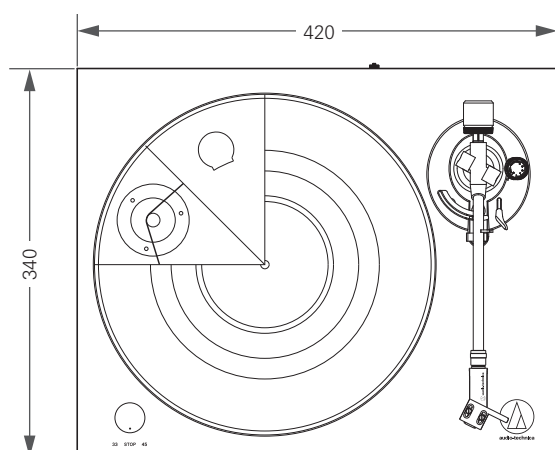

(Unit: mm)

Specifications

Turndown specifications

Type	Belt-drive manual turntable
Motor	DC servo with Active Speed Stabilization
Drive method	Belt drive
Speeds	33-1/3 RPM, 45 RPM
Turntable platter	Aluminum Die Casting
Wow and flutter	< 0.15 % WRMS (33 RPM) at 3 kHz
Signal-to-noise ratio	> 60 dB
Output levels	
“PHONO”	4.0 mV nominal at 1 kHz, 5 cm/sec
“LINE”	200 mV nominal at 1 kHz, 5 cm/sec
Phono Pre-amp gain	35 dB nominal, RIAA equalized

Tonearm specifications

Type	Static balanced straight carbon tonearm
Effective length	223.6 mm
Overhang	18.6 mm
Maximum tracking error angle	Less than 2.0°
Stylus pressure adjustment range	0 to 3.0 g
Applicable cartridge weight range (including headshell)	12 to 17 g

Cartridge and headshell specifications

Cartridge Model	AT-VM95E
Cartridge Type	VM
Recommended load impedance	47,000 ohms
Output voltage	4.0 mV (mV at 1 kHz, 5 cm/sec)
Stylus	0.3 × 0.7 mil bonded elliptical stylus
Cantilever	Aluminum pipe
Tracking force range	1.8 to 2.2 g (standard 2.0 g)
Cartridge weight	6.1 g (0.22 oz)
Headshell model	AT-HS4
Headshell weight	8.5 g (excluding lead wires)
Headshell overhang adjustment	± 5 mm

General specifications

Power supply requirements	100 to 240 V, 50/60 Hz, 0.5 A Max.
Power consumption	110V 60Hz (US) - Working: 1.1 W - Motor off: 1.0 W - Power off: 0.1 W 220V 50Hz (EU) - Working: 1.2 W - Motor off: 1.1 W - Power Off: 0.2 W
AC Adapter	12 V, 0.5 A
Dimensions	420 mm (16.53") × 340 mm (13.38") × 116.9 mm (4.6") (W × D × H)
Weight (without dust cover)	4.72 kg (10.40 lbs)
Accessories included	Dust cover, Platter, Turntable mat, Drive belt, Counterweight, Headshell (AT-HS4) with VM stereo cartridge*, 45-RPM adapter, RCA audio cable (Approx. 1.0 m (3.3')), AC adapter (Approx. 1.5 m (4.9')) (AD-SA1205WE), Dust cover hinges
Replacement stylus (sold separately)	AT-VMN95E
Replacement headshell (sold separately)	AT-HS4
Replacement belt (sold separately)	AT-LPW40WN exclusive belt

* AT-LPW40WN: AT-VM95E

Specifications are subject to change without notice due to improvements.

